



# “The Albuca A-Line Dress”

#MoodAlbucaPattern



Print only this page first to check accuracy. The Mood square above should measure 2 inches. Print “actual size” in “portrait” mode (not auto center). Formatted for both US Letter & A4 paper sizes.



## Formatted for both US Letter & A4 Paper

**Trimless Option:** This is the fastest! No trimming needed! Place left-side margins over right-side margins, overlapping dashed lines and dots. In the same fashion, top margins will overlap bottom margins. Slight unprinted gaps are normal for this method.

**Trimmed Option:** This removes any unprinted gaps. Trim along the top and right margins at the dashed lines. Overlap the trimmed margins to the untrimmed margins, matching dashed lines and dots.

**Tip!** Build rows first, then join the rows together as you go.

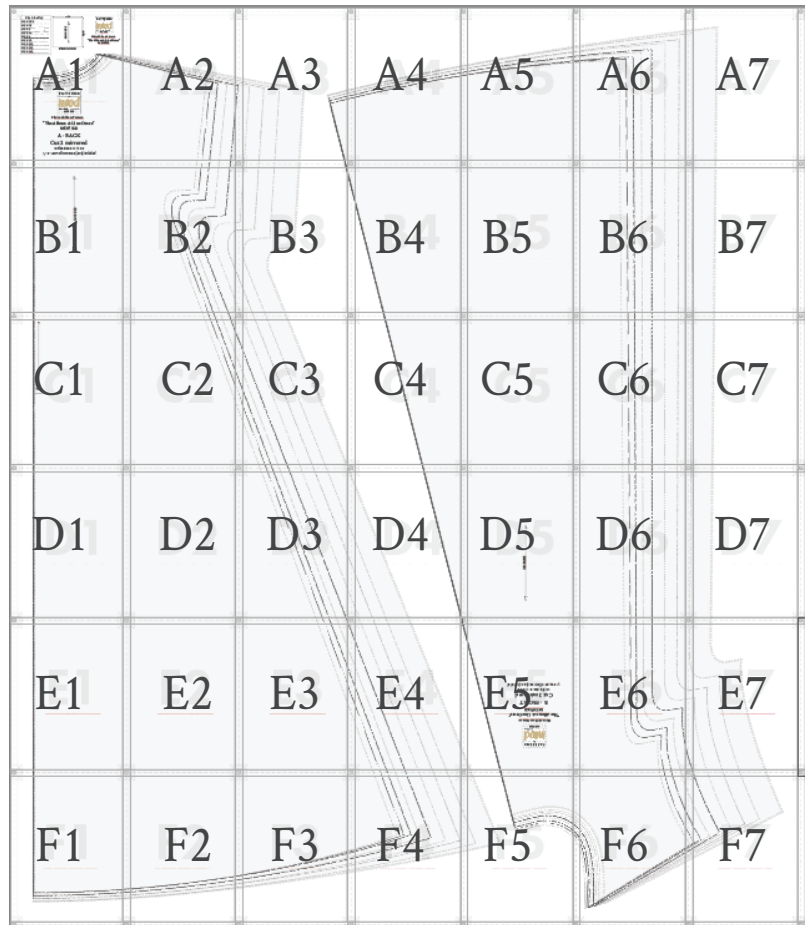



## “The Albuca A-Line Dress”

Ladies Sizes XXS to 4XL

### BODY MEASUREMENTS IN INCHES (Chart 1)

SINGLE SIZES	XXS	XS	S	M	L	XL	2XL	3XL	4XL
BUST	31	31.5 - 33	33.5 - 35	35.5 - 37.5	38 - 40.5	41 - 44.5	45 - 48.5	49 - 52.75	53 - 59.5
WAIST	23	23.5 - 25	25.5 - 27	27.5 - 29.5	30 - 32.5	33 - 36.5	37 - 40.5	41 - 44.75	45 - 51.5
HIPS	34	34.5 - 36	36.5 - 38	38.5 - 40.5	41 - 43.5	44 - 47.5	48 - 51.5	52 - 56	56.5 - 63.5

### APPROXIMATE FINISHED GARMENT MEASUREMENTS - IN INCHES (Chart 2)

SINGLE SIZES	XXS	XS	S	M	L	XL	2XL	3XL	4XL
BUST	33	35	37	39.5	42.5	46.5	50.5	54.75	61.5
WAIST	38	40	42	44.5	47.5	51.5	54.5	58.75	65.5
HIPS	44	46	48	50.5	53.5	57.5	61.5	66	73.5

Size guide is based on the suggested design & wearing ease for this style. You can also choose the size according to your desired finished garment measurements, blending between sizes as needed. For best results, sew a test garment in a similar fabric to adjust your pattern.

**Recommended Fabric:** Luxury Burnout Brocade (Self) , Polyester Double Georgette (Lining).

We love creating these free patterns for the community and we want to keep them free! In return, we hope you check out MoodFabrics.com for your next project!

Want to use one of our patterns to make a garment to sell? Our patterns are royalty-free! We just ask that you credit us with:  
MoodSewciety.com  
or  
MoodFabrics.com  
in your product description.

FOR SEWING INSTRUCTIONS  
AND MORE INFORMATION:

Scan the QR code or visit  
MoodSewciety.com and search  
“MDF368”



1/2" seam allowances (SA's) included  
unless stated otherwise.

REMEMBER TO SHARE YOUR  
MADE WITH MOOD LOOK!

Tag us and use:

**#MoodAlbucaPattern**

for a shot at being featured on our  
social media

-  @mood.fabrics
-  @moodfabrics
-  @Mood\_Fabrics
-  @moodfabrics
-  @moodfabrics



# “The Albuca A-Line Dress”

Ladies Sizes XXS to 4XL

<b>A</b>	BACK FABRIC - CUT 2 MIRRORED LINING - CUT 2 MIRRORED
<b>B</b>	FRONT FABRIC - CUT 2 MIRRORED LINING - CUT 2 MIRRORED

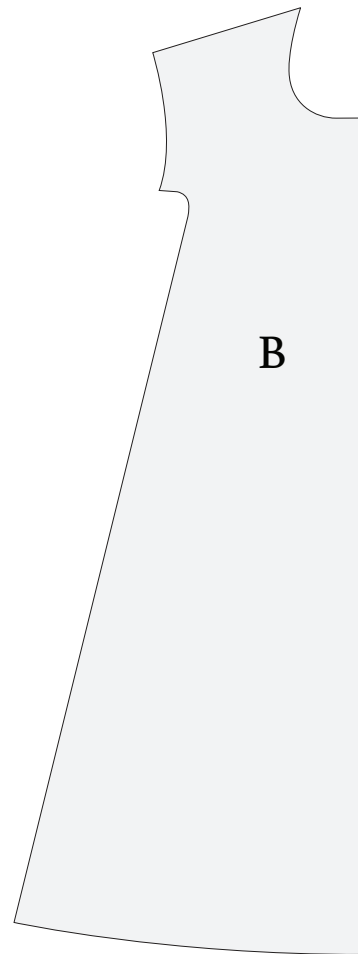
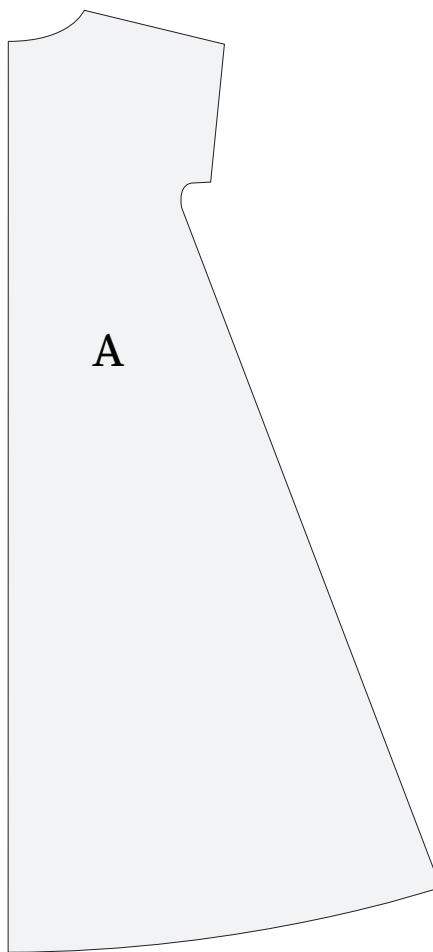

Size Line Key	
SIZE XXS	-----
SIZE XS	- - - - -
SIZE S	.....
SIZE M	_____
SIZE L	.....
SIZE XL	- - - - -
SIZE 2XL	.....
SIZE 3XL	_____
SIZE 4XL	.....

### Size Line Key

SIZE XXS	-----
SIZE XS	-▲▲▲▲▲-
SIZE S	.....
SIZE M	-----
SIZE L	.....
SIZE XL	-▲▲▲▲▲-
SIZE 2XL	.....
SIZE 3XL	-----
SIZE 4XL	.....

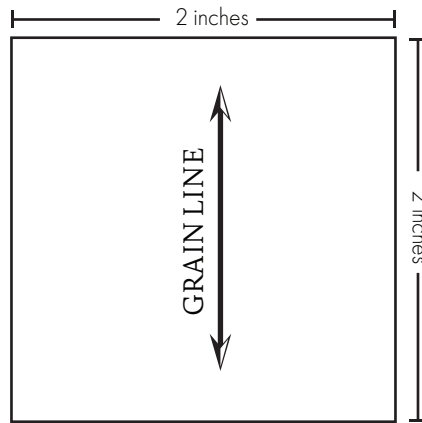

2" BOX TEST PIECE



#MoodAlbucaPattern  
"The Albuca A-Line Dress"  
MDF368

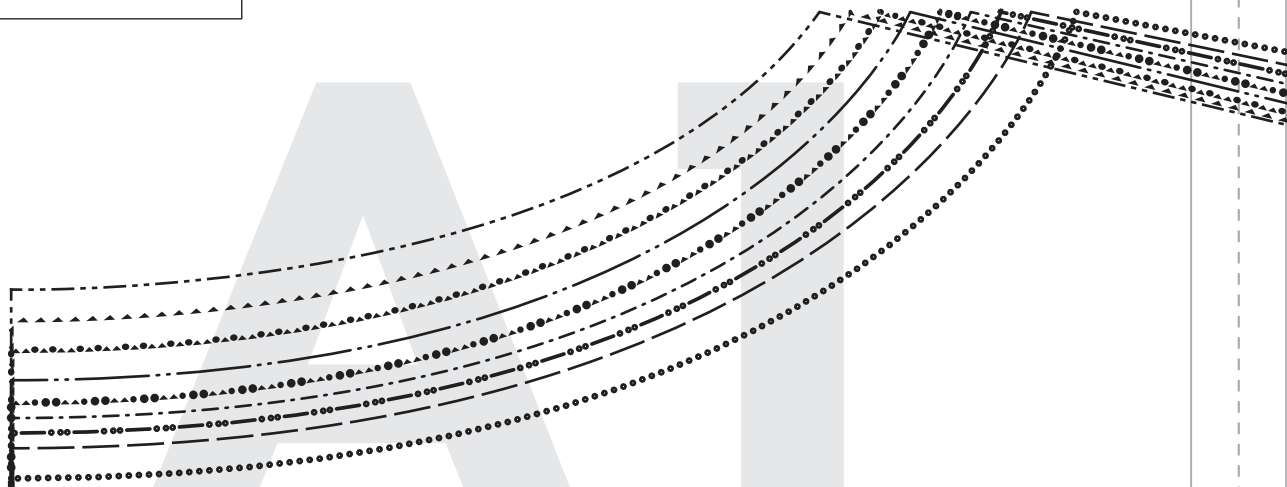

#MoodAlbucaPattern

## "The Albuca A-Line Dress" MDF368

### A - BACK

### Cut 2 mirrored

Ladies Sizes XXS to 4XL

1/2" seam allowances (SA's) included

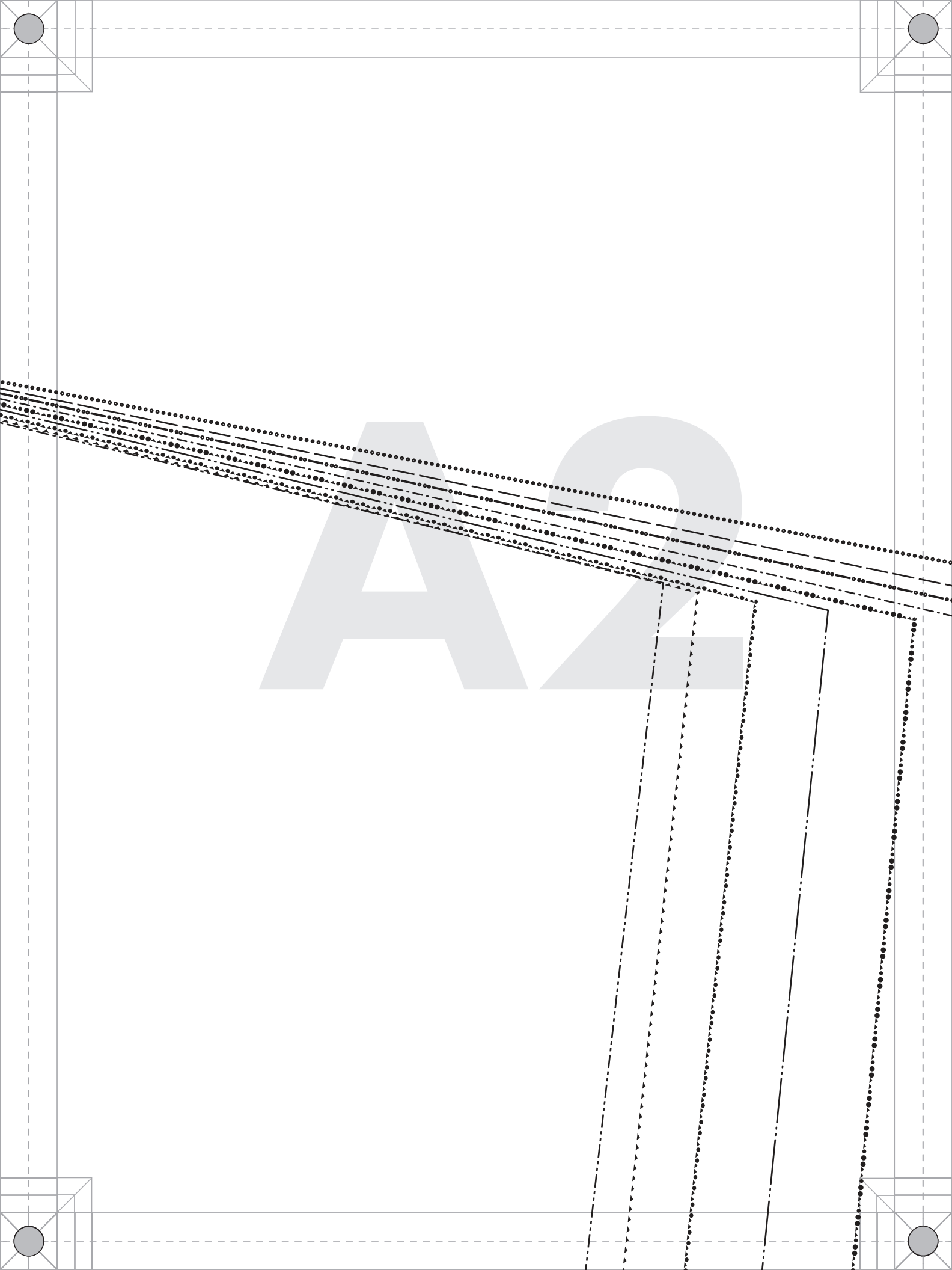

A3

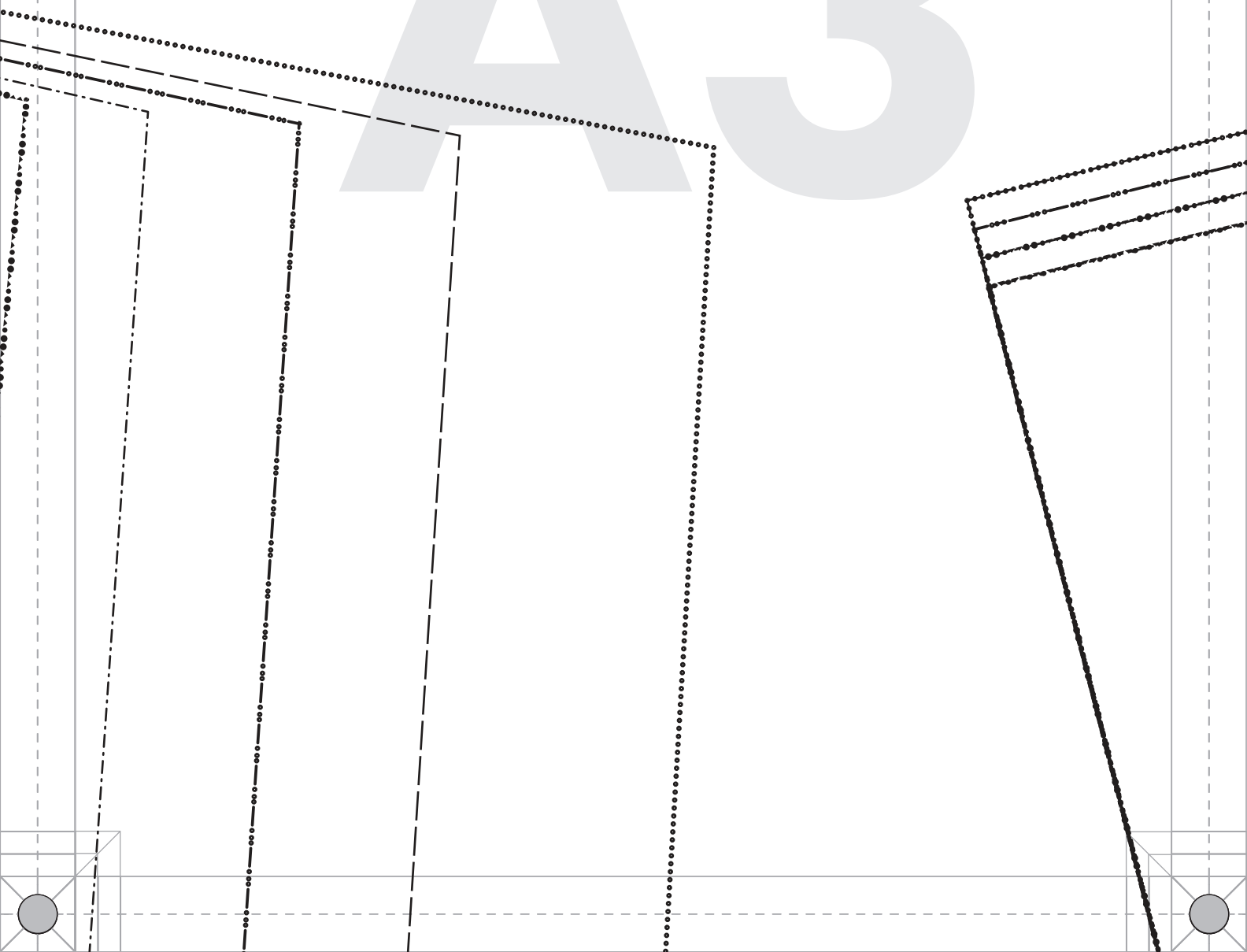

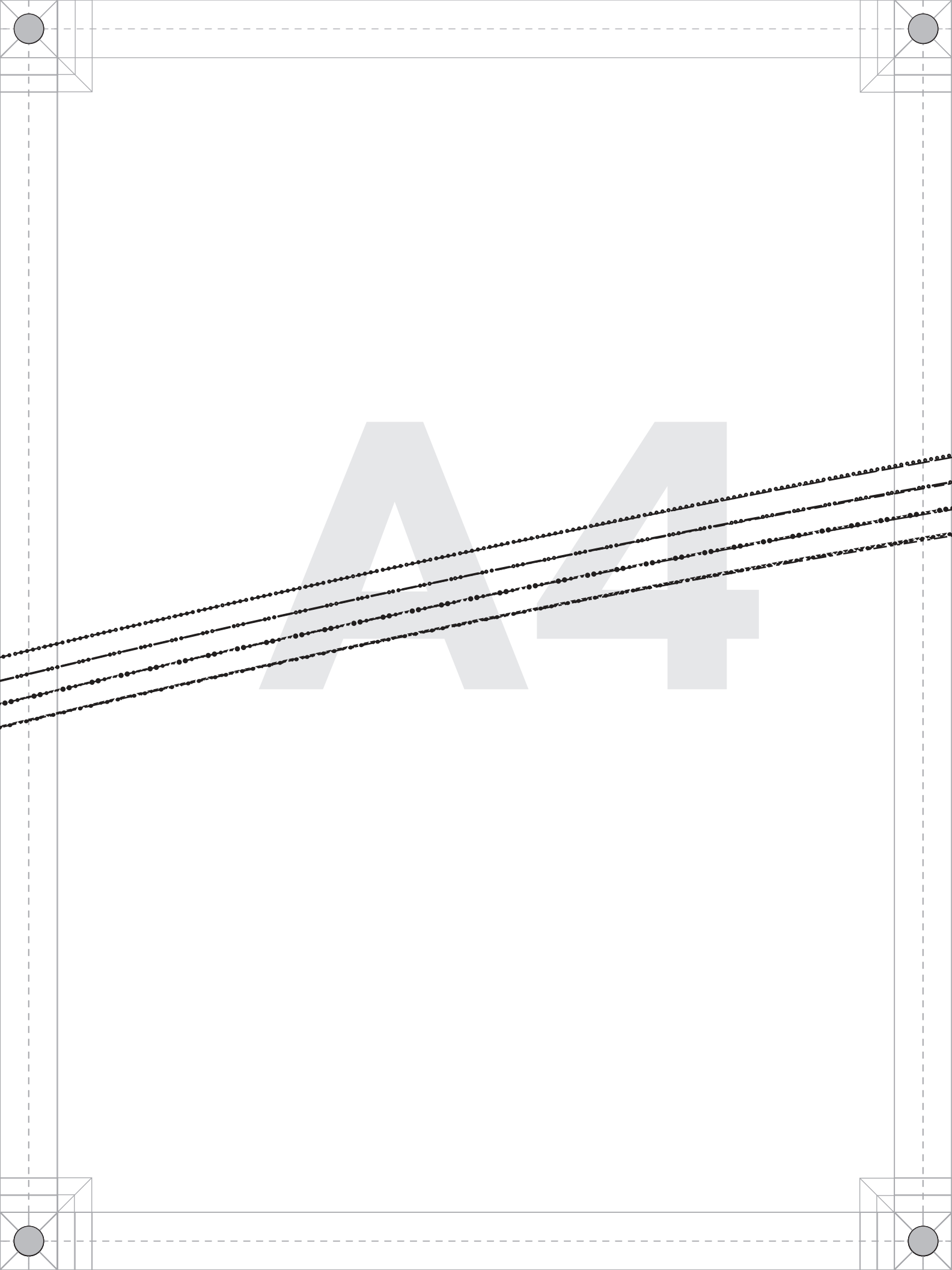

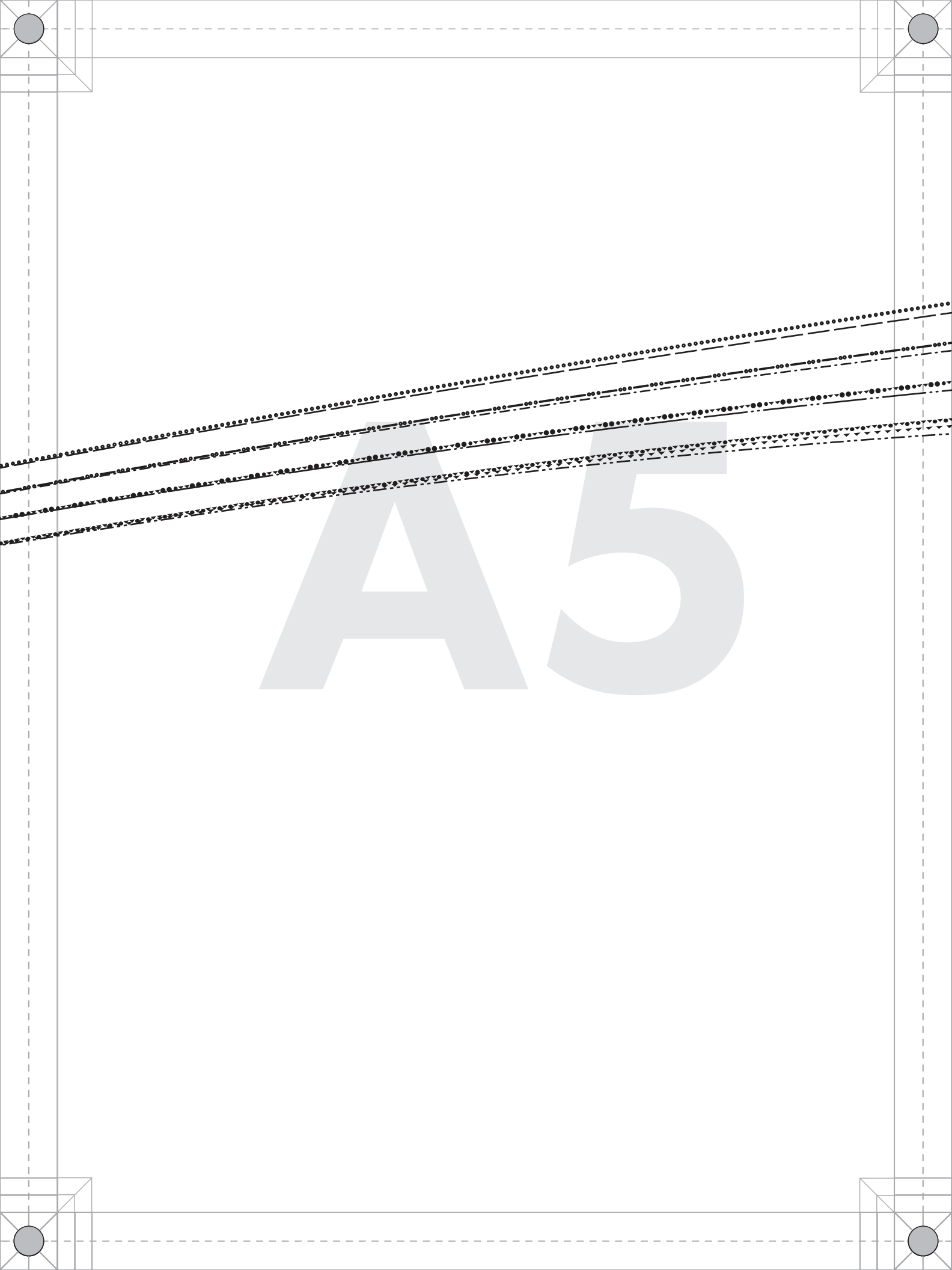



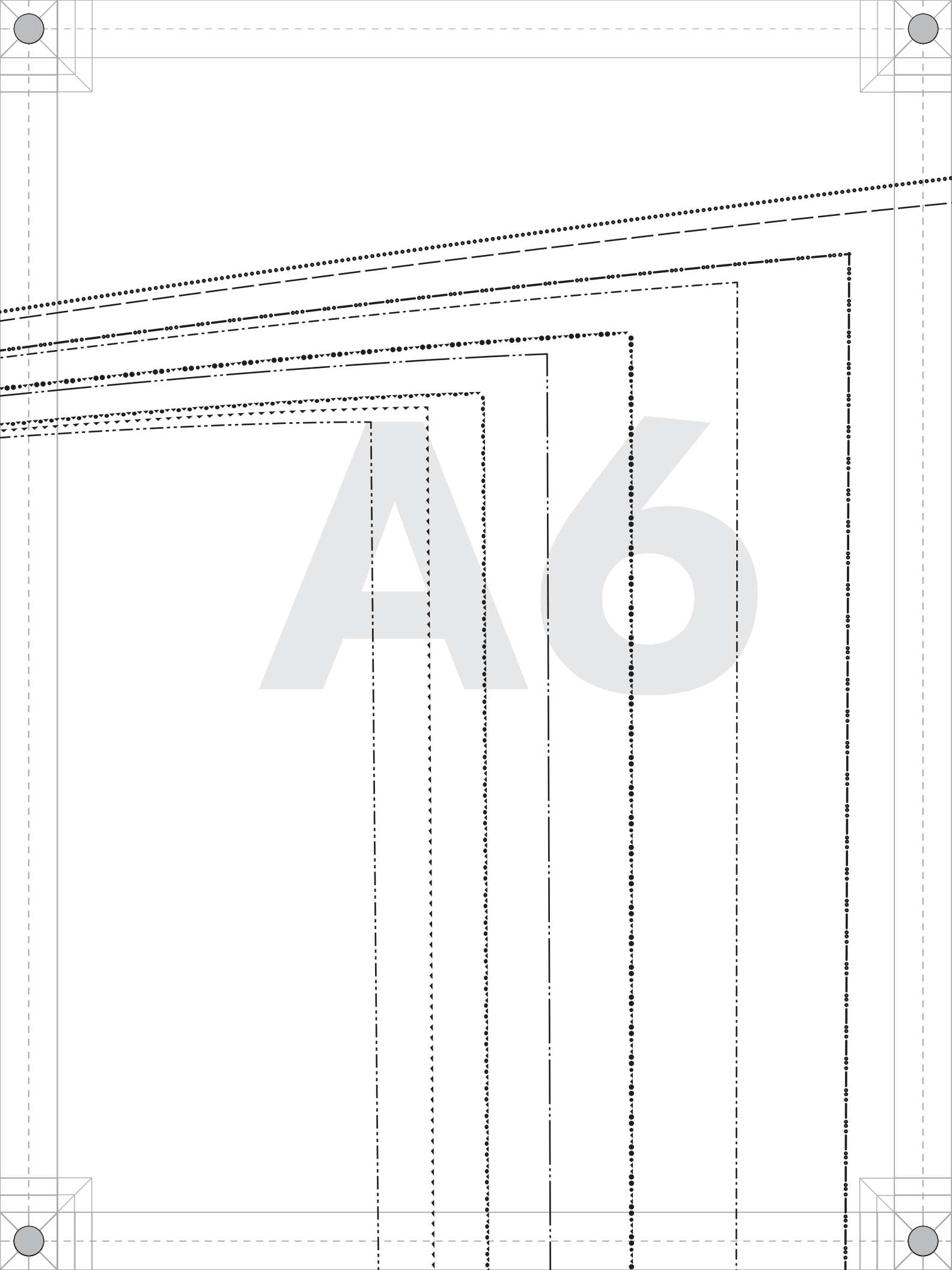

A6

A7

B1

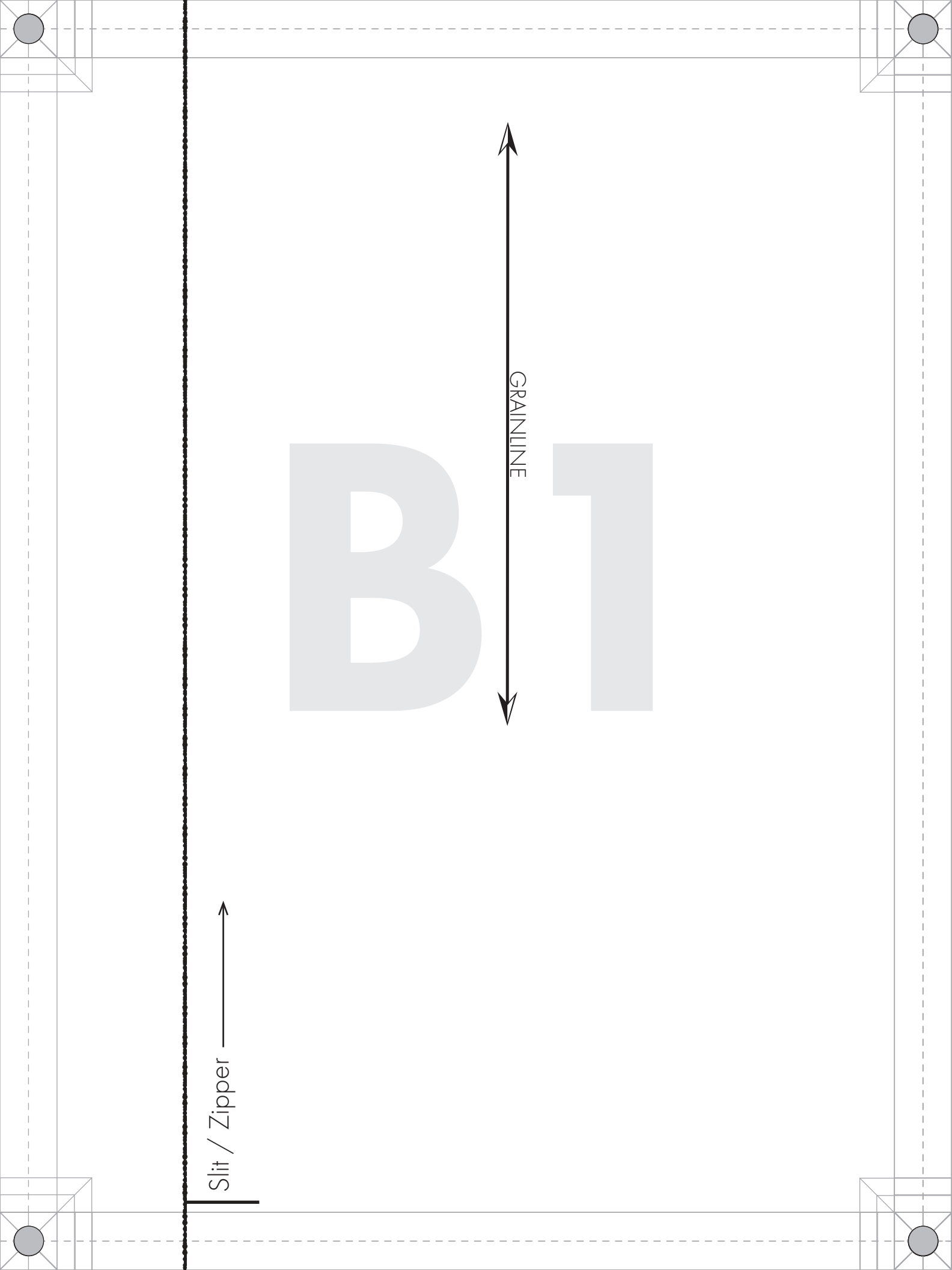

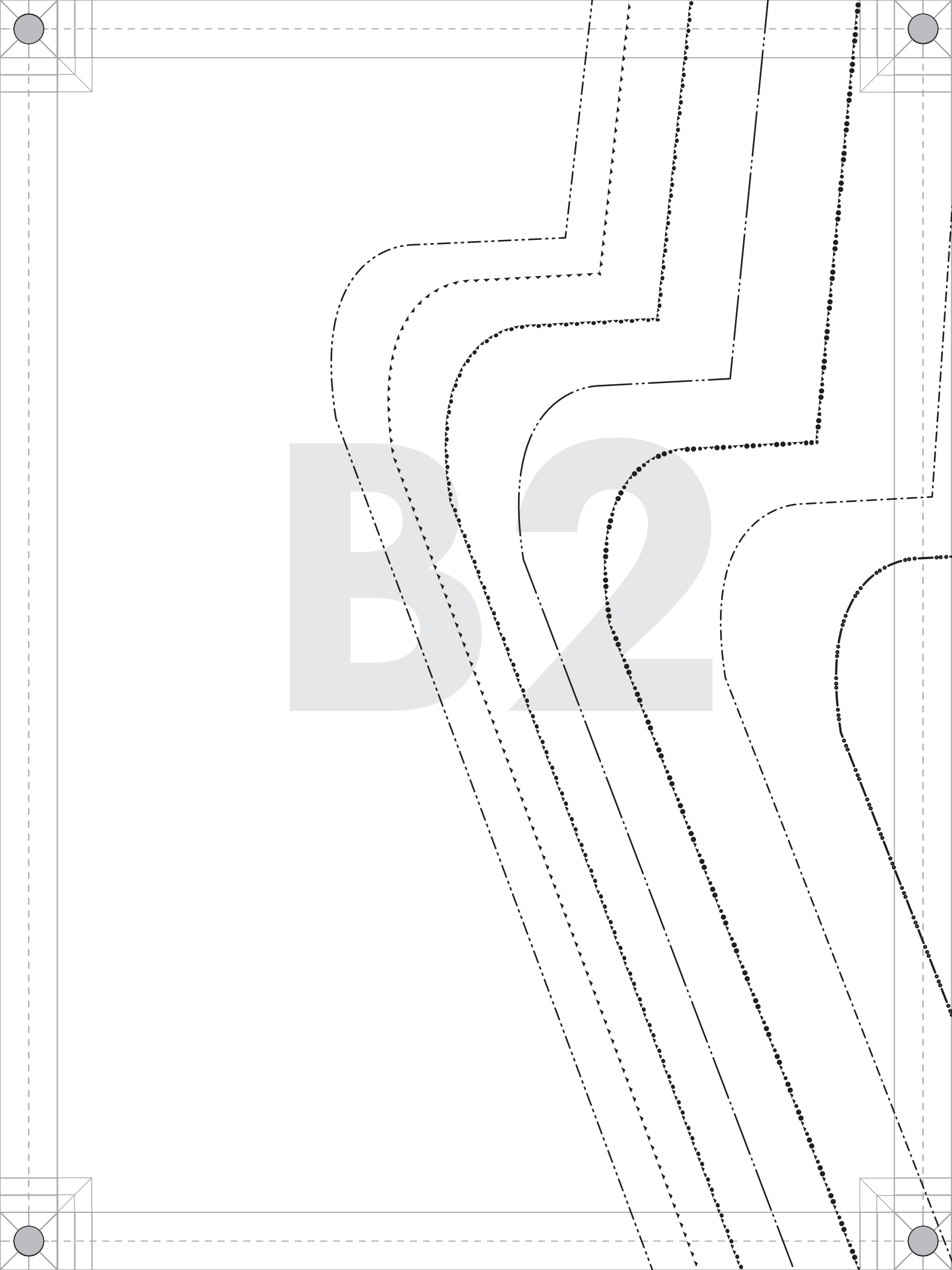

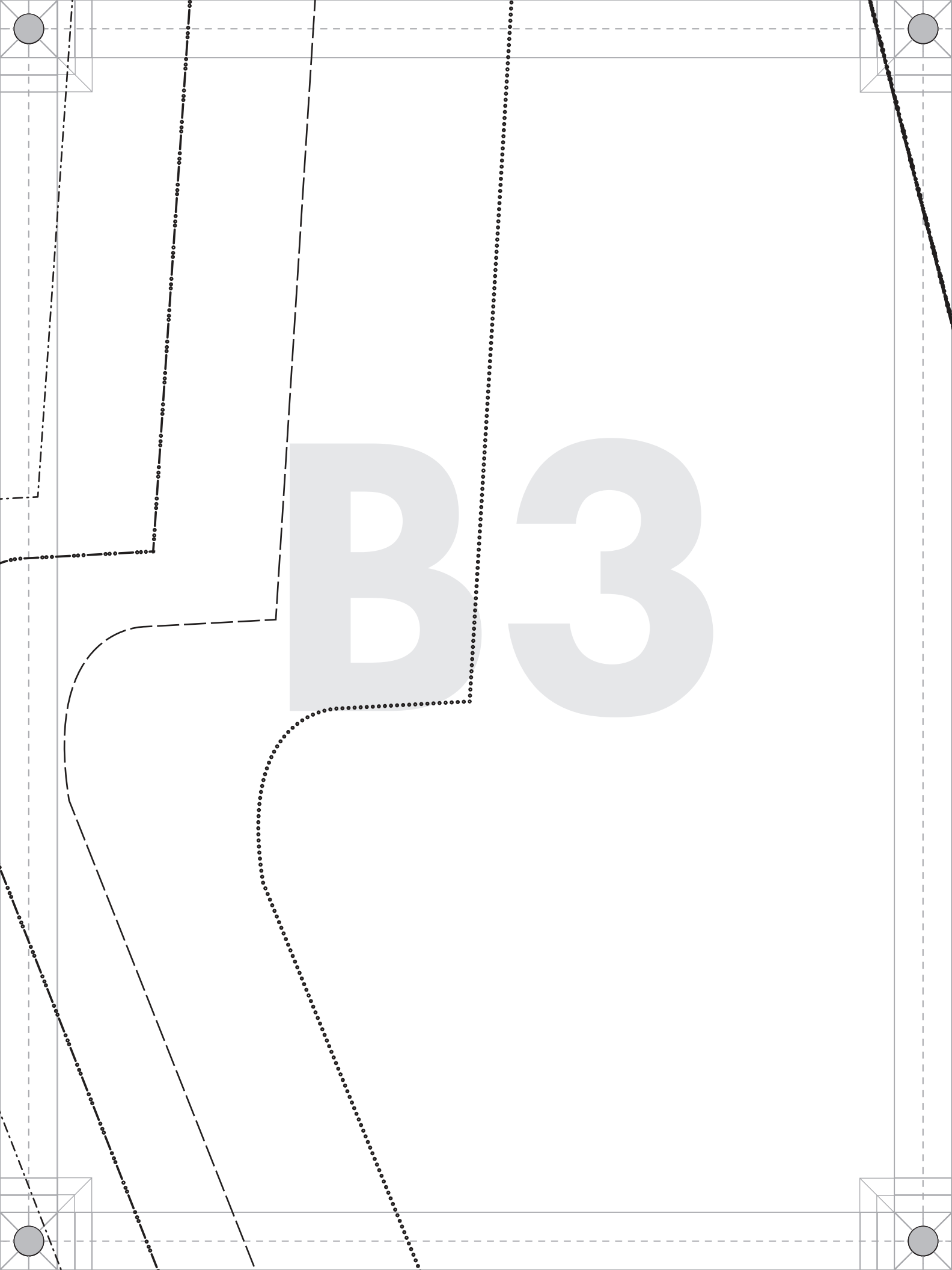

B4

B5

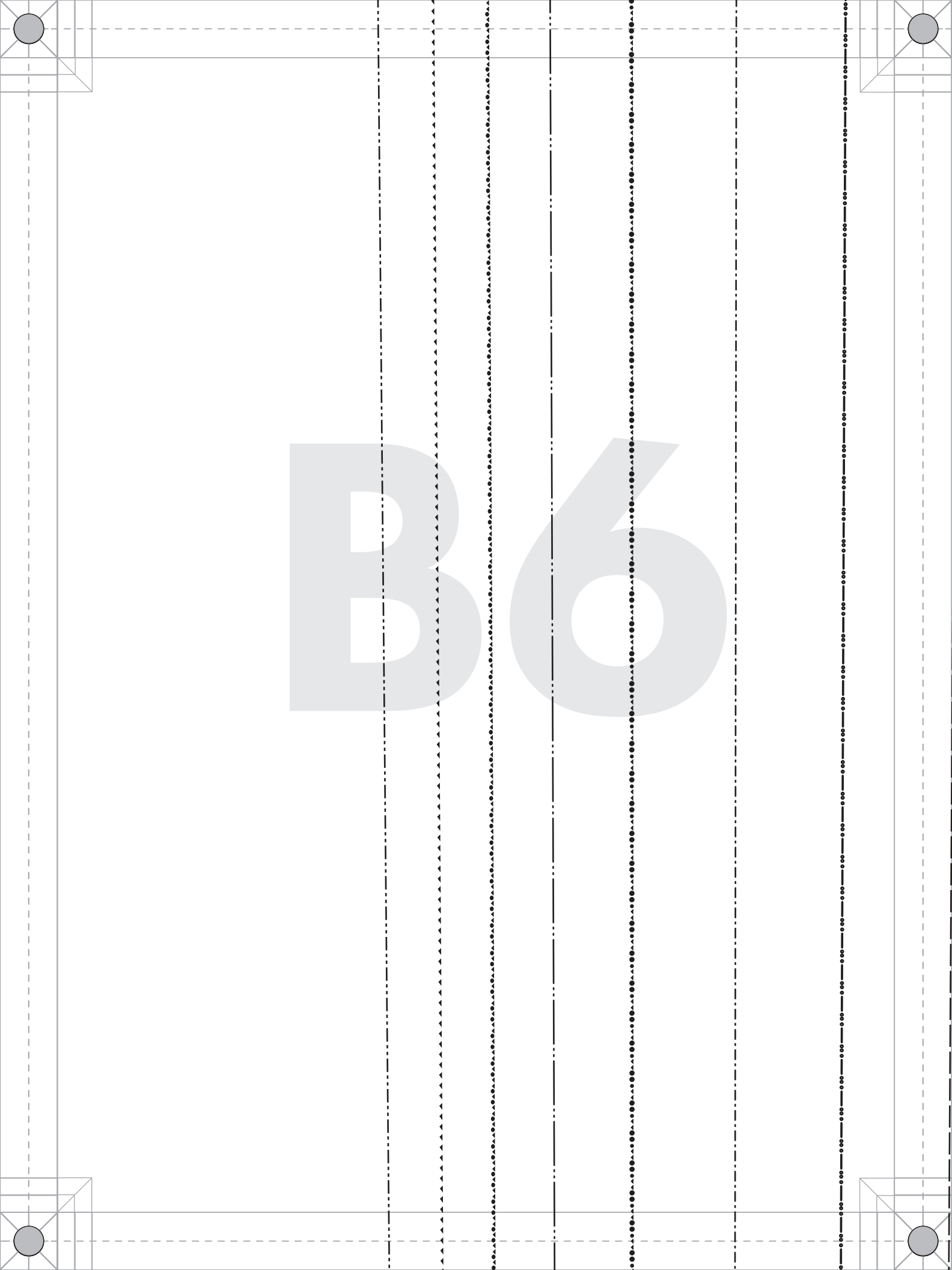

B b



B7

C1

C2

C3

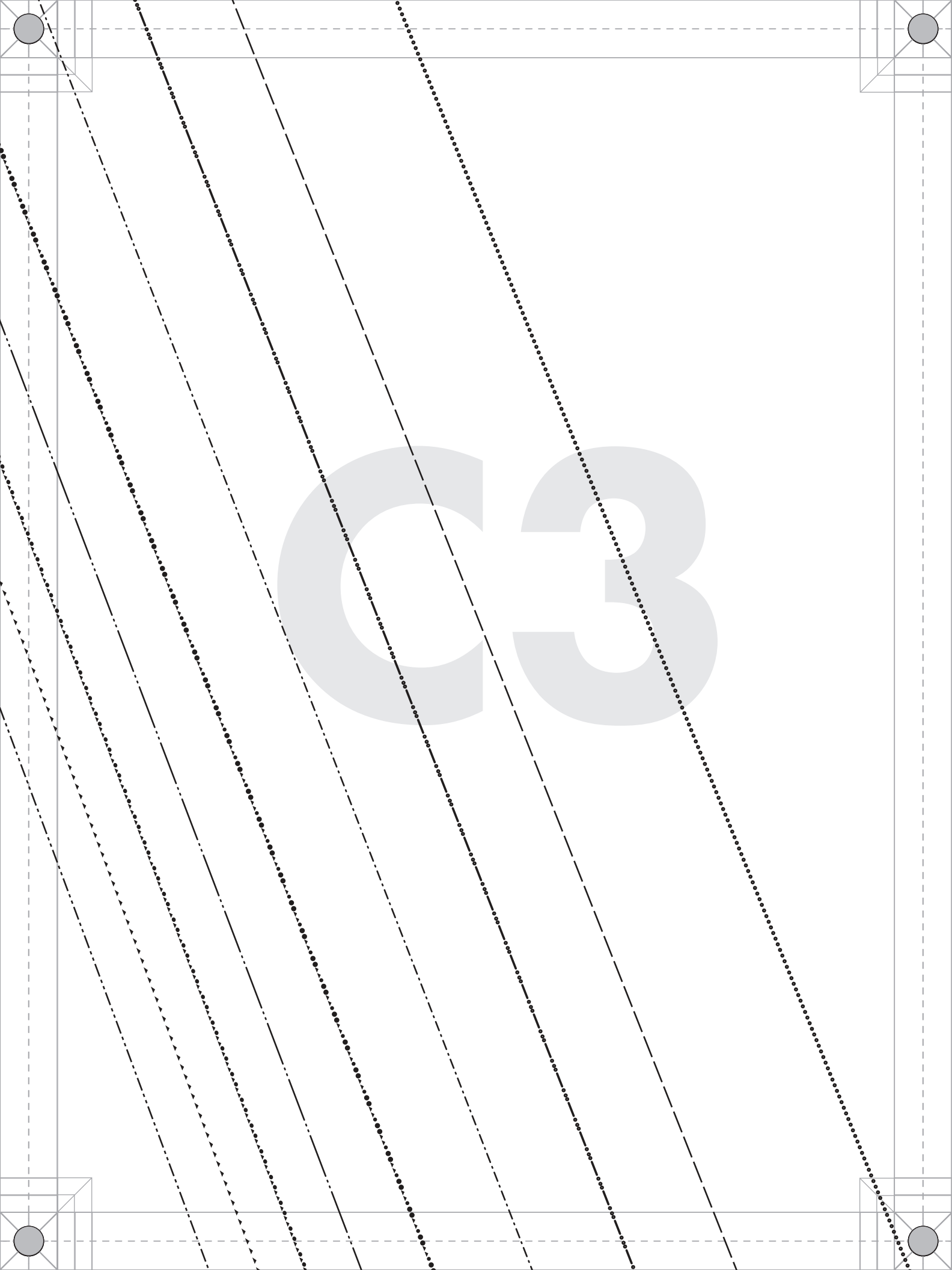

C4

C5

C6

C7



D1

D2

DS3

D4

D5

GRAINLINE



D 6

D7

E1



E2

E3

E4

Ladies Sizes XXS to 4XL  
1/2" seam allowances (SA's) included

**Cut 2 mirrored**

**B - FRONT**

**MDF368**

**"The Albuca A-Line Dress"**

#MoodAlbucaPattern



E e

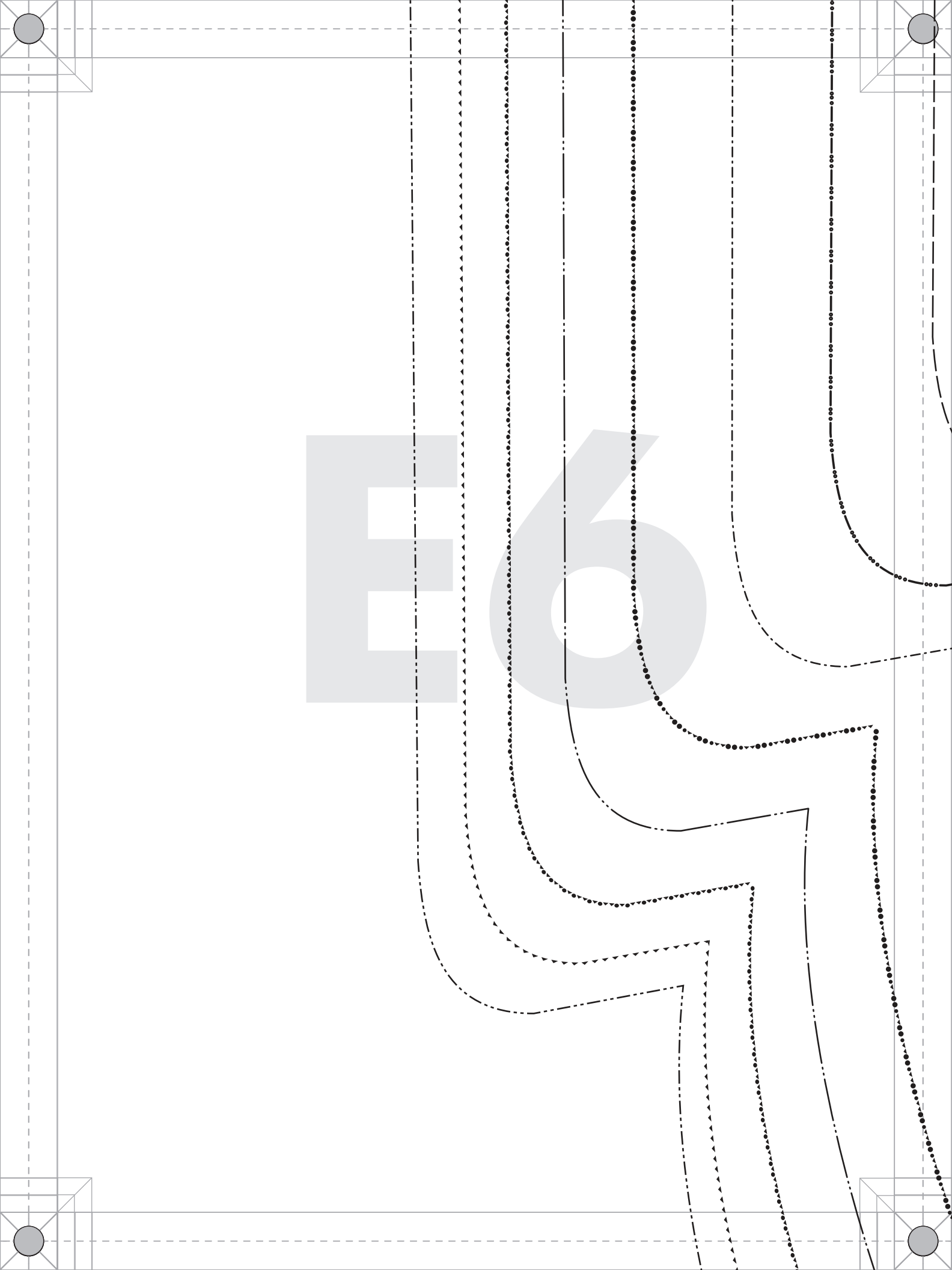
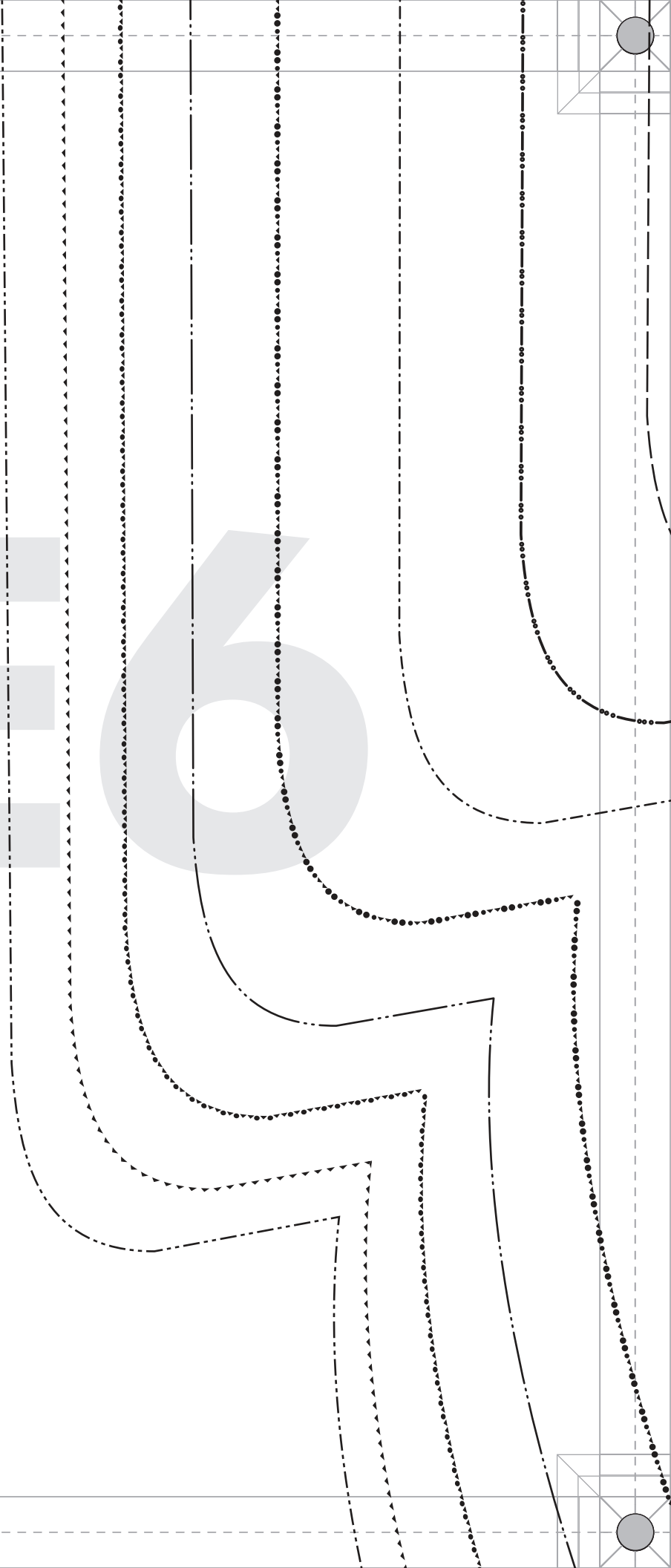

EEZ

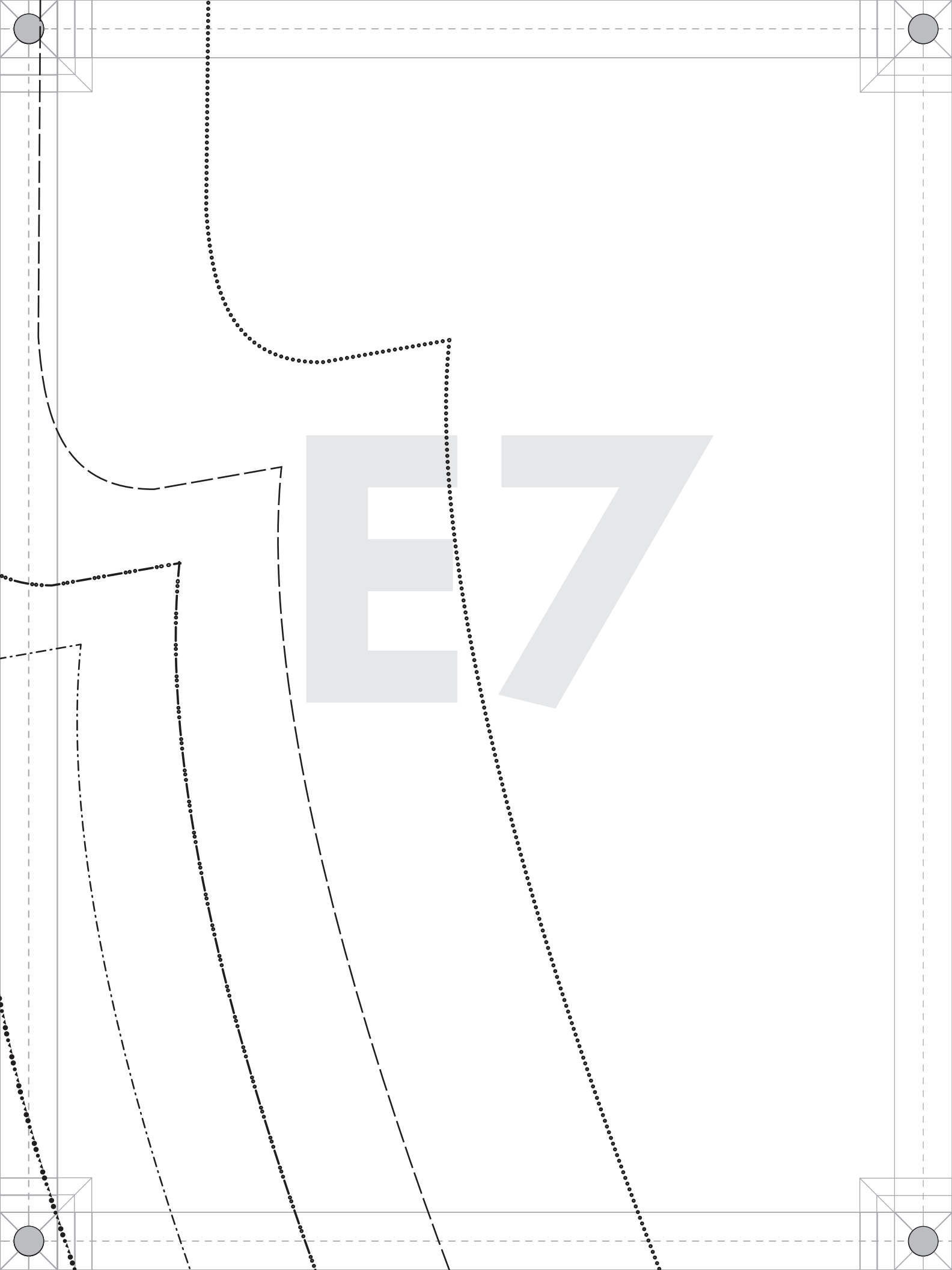

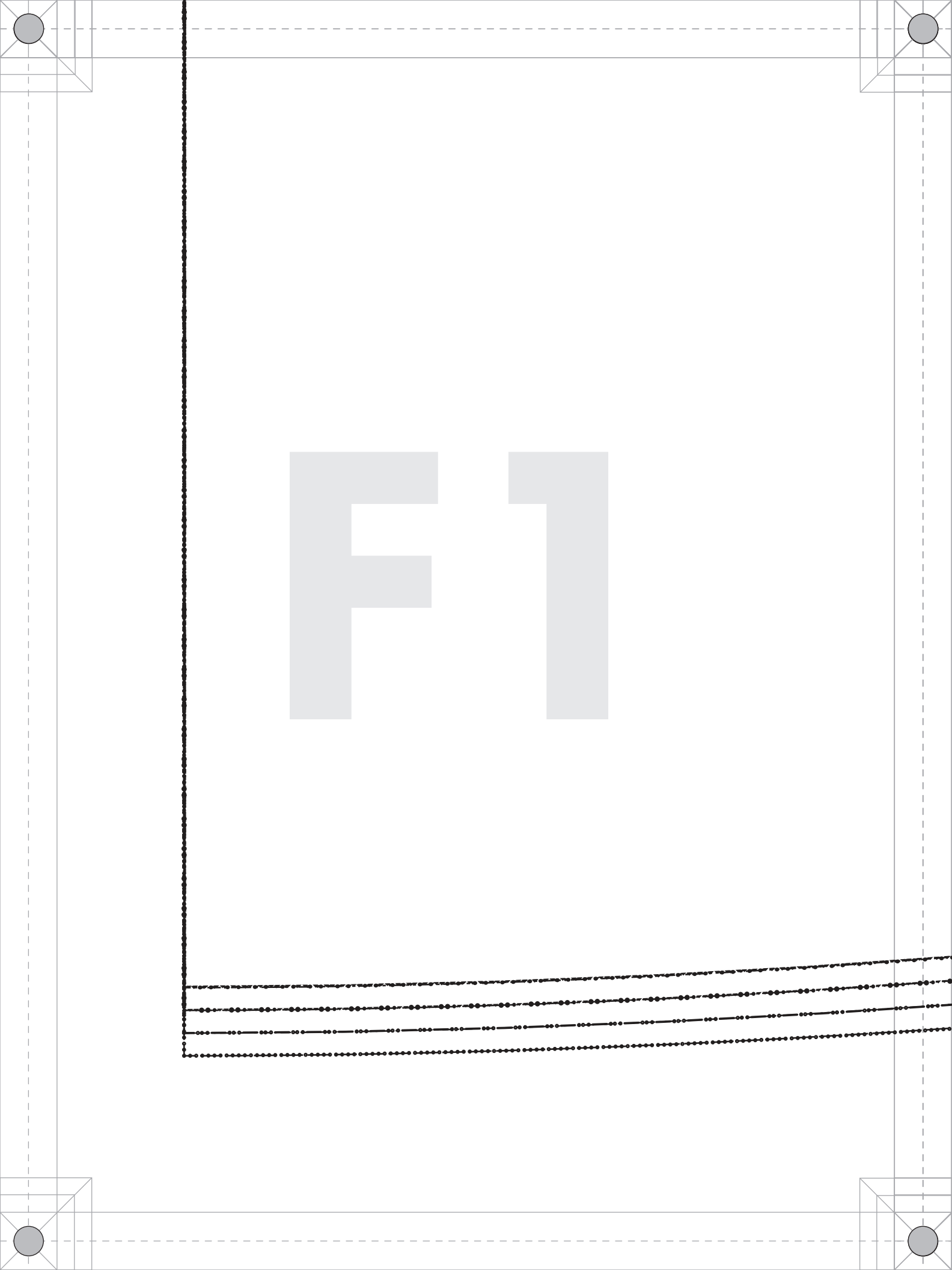

F1

F2

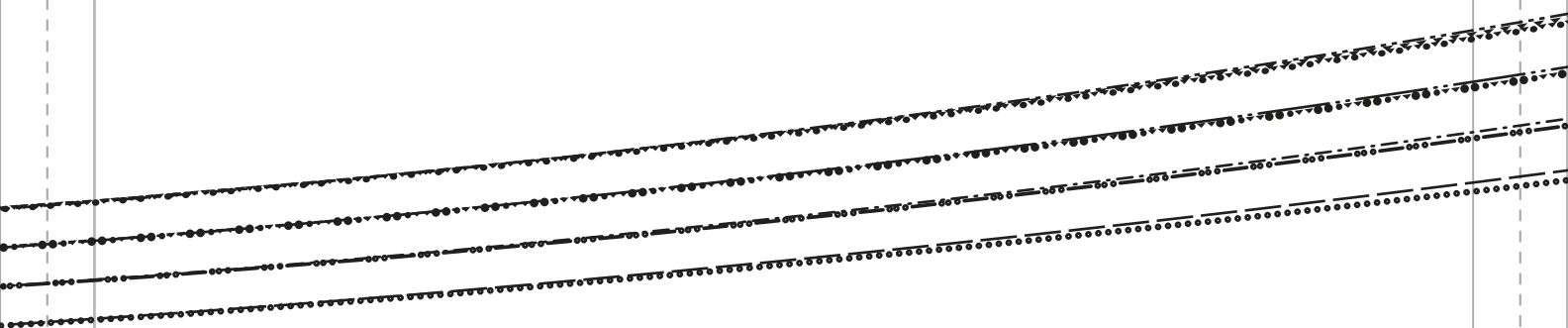



F3



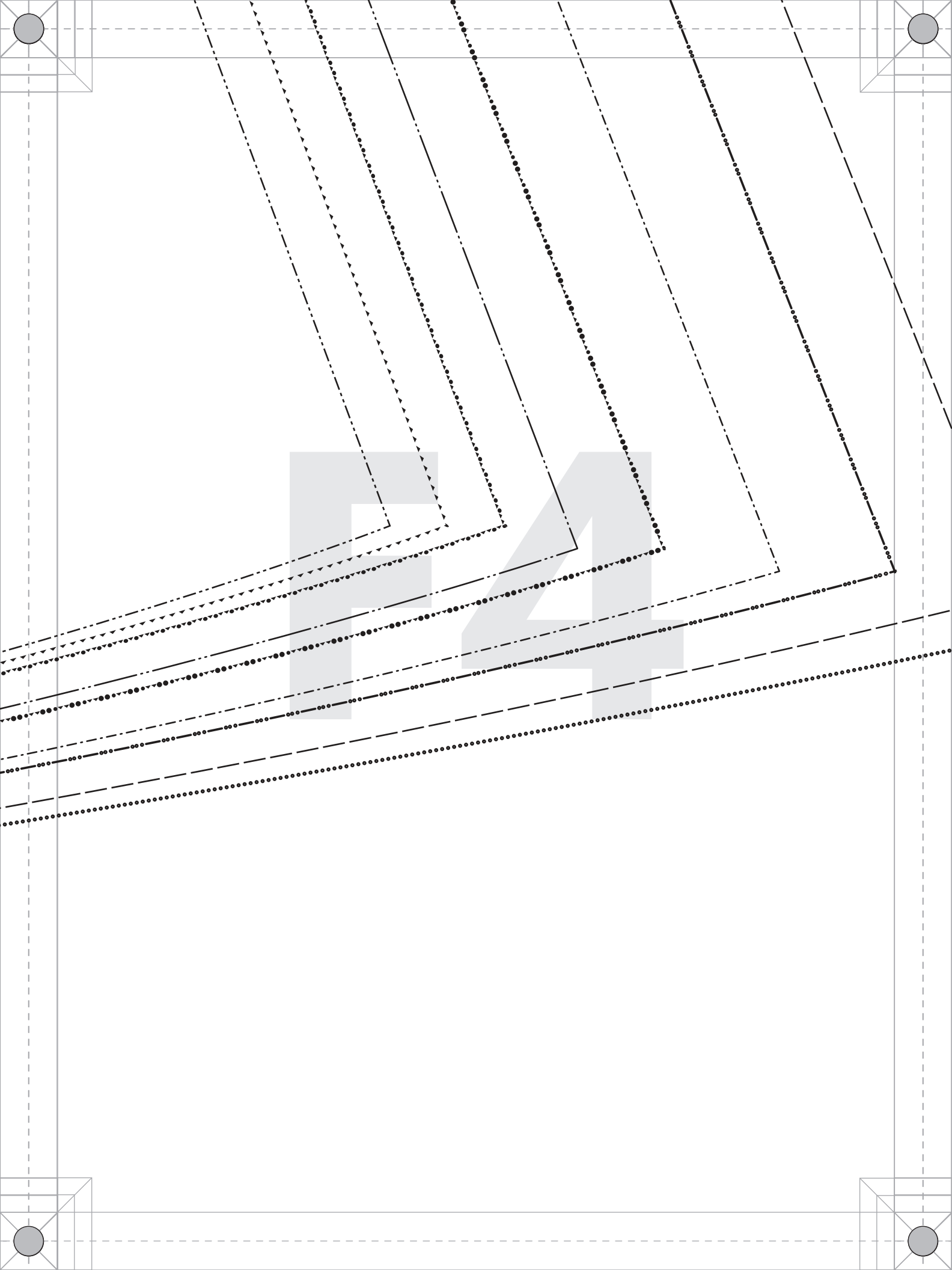

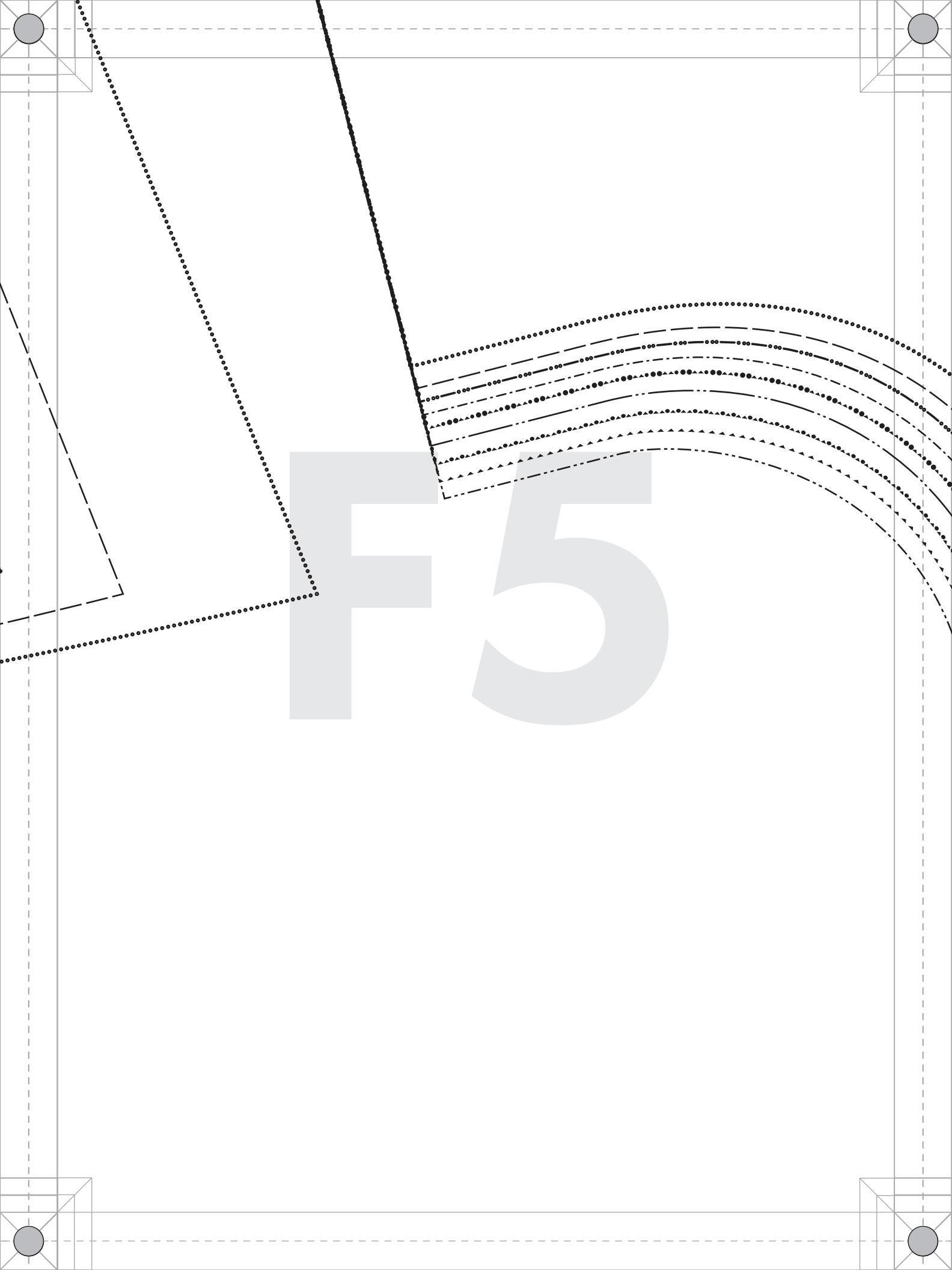

F6

